



Description

S1108SC combines a dedicated current mode PWM mode controller with a 1.9 Ω /630V COOL MOSFET. S1108SC has high efficiency, low standby power consumption, low EMC and low cost. It is applied to the off-line flyback converter in the range of 18W output power.

S1108SC offers comprehensive protection functions, including Cycle-by-Cycle current limitation (OCP), over temperature protection (OTP), Over voltage clamp (OVP) and under voltage lockout (UVLO) on VCC.

S1108SC is offered in SOP8 package.

Features

- ⌘ Digit frequency shuffling technology to improve EMI performance.
- ⌘ Fixed 65kHz PWM switching frequency.
- ⌘ Leading-edge blanking on current sense.
- ⌘ Internal synchronized slope compensation.

- ⌘ Low standby power consumption (<75mW@AC 230V)
- ⌘ Soft-start to reduce MOSFET Vds stress during power on
- ⌘ Comprehensive protection function
 - 1、 Under voltage locked with hysteresis (UVLO) on VCC.
 - 2、 Over voltage protection (OVP) on VCC.
 - 3、 Cycle-by-Cycle current limitation.
 - 4、 Over load protection (OLP)
 - 5、 Over temperature protection (OTP)
 - 6、 Current limitation compensation to obtain the same output current in universal ac line input
- ⌘ Low start-up current (<10uA@VCC=12V)

Applications

- ⌘ Cell Phone Charger
- ⌘ Digital Cameras Charger
- ⌘ Battery charger

Application Circuit

Two large value resistors are connected to VCC capacitor in startup circuit .

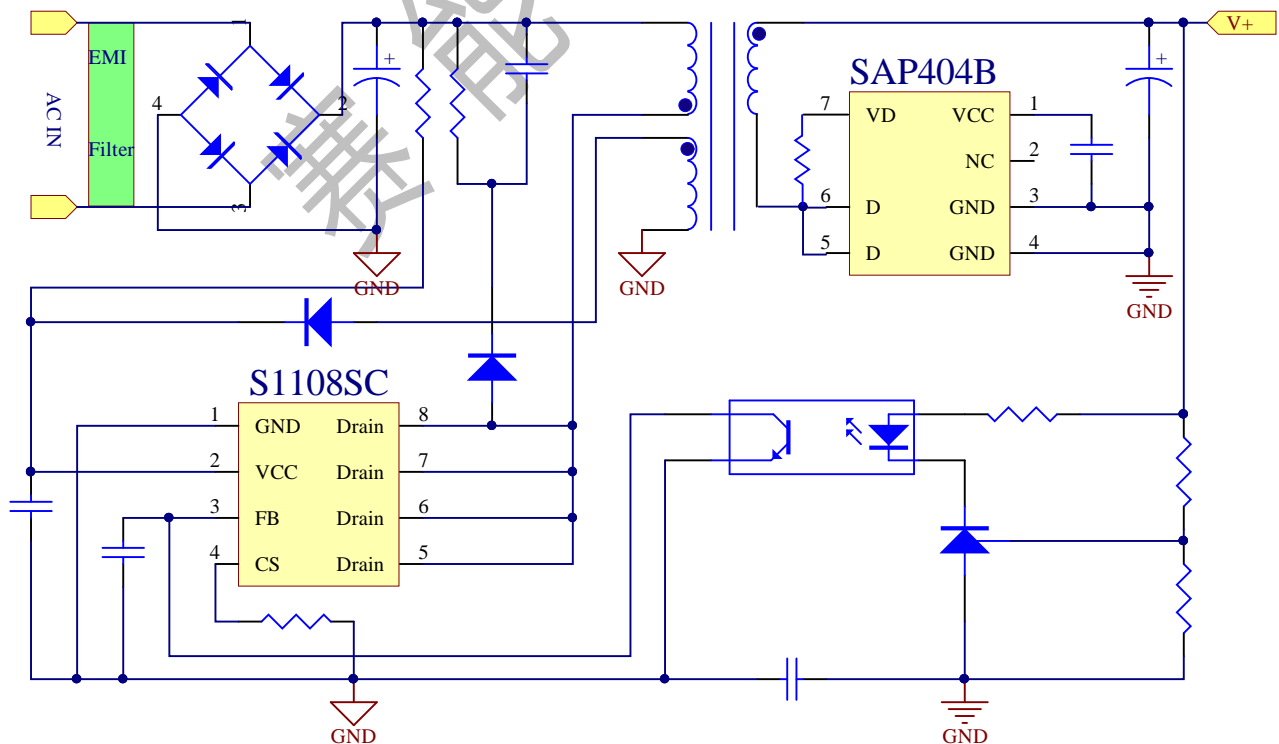

**Output table**

Product	230VAC±15%	85-265VAC
S1108SC	Open Frame1	Open Frame1
	20W	18W

Note:Maximum practical continuous power is in the open frame structure at 45°C ambient temperature. The output power would be higher possible with extra heat sink or air circulation to reduce thermal resistance.

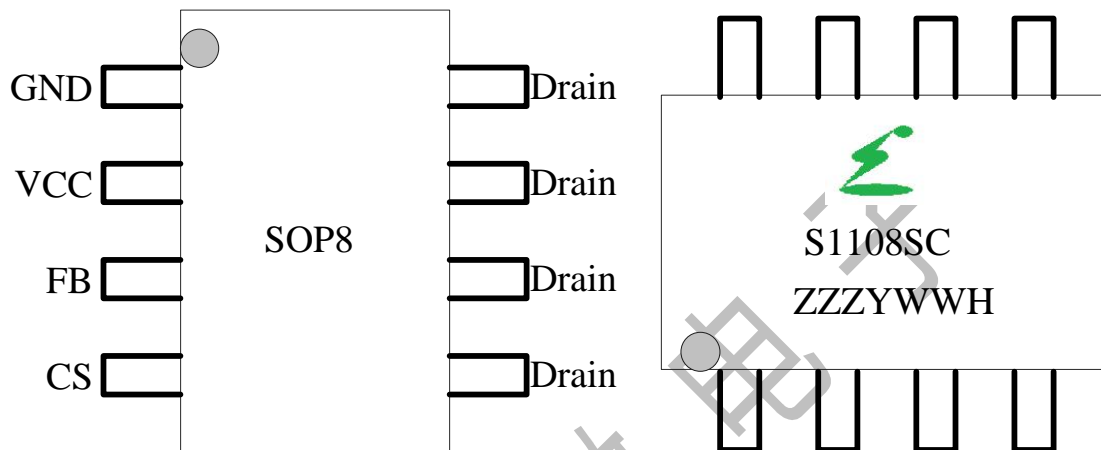
Pin Assignment & Marking Information

C:	mos code
ZZZ:	LOT NO
Y:	Year code (2020=A)
WW:	week code (01-52)
H:	FAB code

Ordering Information

Part number	Package	version number
S1108SC	SOP8	

Pin Description

Pin name	Pin number	Pin type	Function description
GND	1	GND	ground
VCC	2	Power	Power Supply
FB	3	Feedback Input	Feedback Input Pin.The PWM duty cycle is determined by this pin voltage level and current-sense signal at Pin 4.
CS	4	Current Monitoring	Current Sensing
Drain	5,6,7,8	Internal MOSFET Drain	Internal HV MOSFET Drain.Connected to the primary lead of the transformer

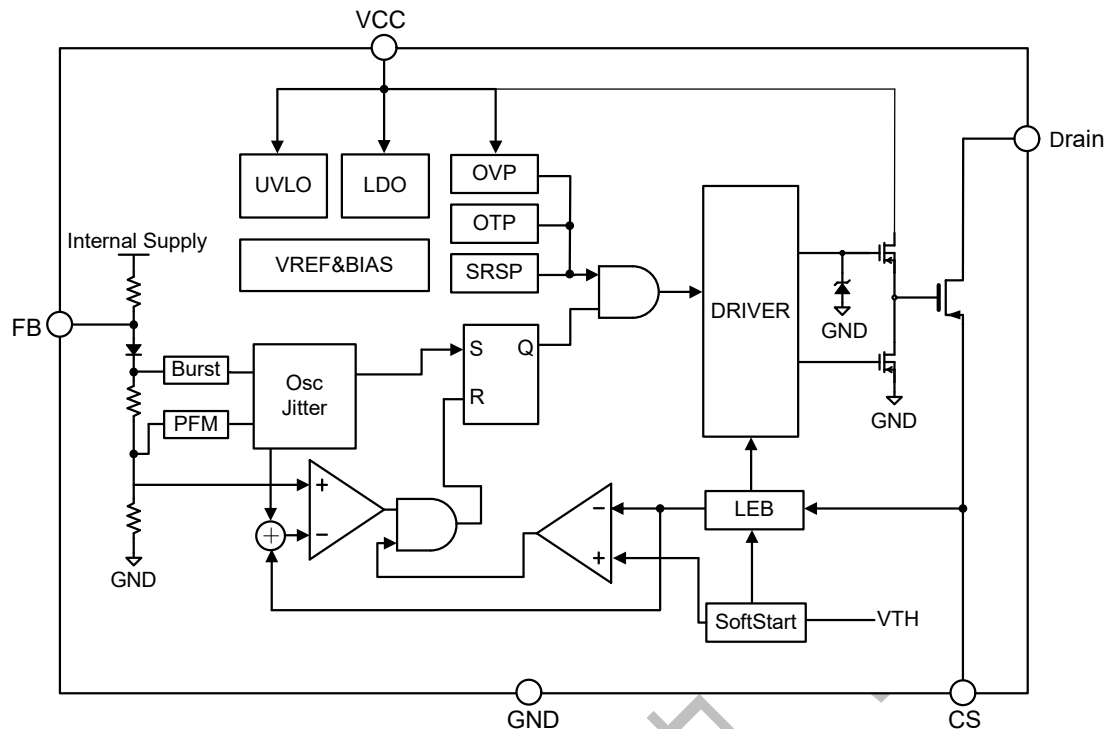
**Block Diagram****Absolute Maximum Rating**

Symbol	Parameter	Value	Unit
Drain	Internal HV MOS Drain voltage	-0.7~630	V
VFB	FB Input Voltage	-0.3~7	V
VCS	Current-sense Input Voltage	-0.3~7	V
Tj	Operating Junction Temperature	-20~150	°C
Tstg	Storage Temperature	-40~150	°C
Vcc-clamp	VCC Clamp Voltage	41	V
Icc	VCC DC Clamp Current	10	mA

Note: Stresses above absolute maximum ratings may cause permanent damage to the device. Exposure to absolutely maximum-rated conditions for extended periods may affect device reliability.

Recommended Operating Conditions

Symbol	Parameter	Value	Unit
VCC	VCC supply voltage	9-41	V
Ts	Operating shell temperature	-10-110	°C
Drain	Internal HV MOS Drain voltage	-0.7-630	V

ESD information

Symbol	Test condition	Value	Unit
Vesd-HBD	Human model Except Drain	2	KV
Vesd-MM	Machine Model	150	V

Thermal characteristics

Characteristics	Symbol	Rating	Unit
Thermal resistance, Junction to shell	R θ jc	190	°C/W

**Electrical Characteristics** ($T_A = 25\text{ }^\circ\text{C}$, if not otherwise noted)

VCC						
Symbol	Parameter	Test Condition	MIN	Type	MAX	Unit
VCC-Op	Operation Voltage		9		41	V
UVLO-On	Turn-Off threshold		6.8	7.8	8.2	V
UVLO-Off	Turn-on threshold		13	13.4	16.5	V
I_VCC-ST	Start-up Current	VCC=12V		3	10	uA
I_VCC-Op	Operation Current	VCC=16V;FB=2.0V		1.5		mA
VCC-OVP	VCC over voltage protection		41		43	V
FB						
VFB_Open	V_FB Open Loop Voltage			5.7		V
IFB_Short	FB Pin Short Current	FB Shorted to GND	90	150	300	uA
VTH_PL	Power limiting FB Threshold		2	2.5		V
TD_PL	Power limiting Debounce			60		ms
ZFB_IN	Input Impedance			30		kΩ
Max_Duty	Maximum duty cycle			75		%
CS						
TLEB	Leading edge Blanking Time		100	400	750	ns
Zsense	Input impedance			40		kΩ
VTH_OC	OCP threshold	Duty=0	0.62	0.65	0.68	V
Oscillator Section						
Fosc	Frequency	Oscillation	60	66.5	73	khz
Fosc_BM	Burst mode frequency		17	25	28	khz
HV MOSFET						
BVdss	breakdown voltage		630			V
Rds_on	Static Drain to Source on resistance	S1108SC		1.9		Ω



Application Information

S1108SC combines a dedicated current mode PWM mode controller with a 4A/630V MOSFET. S1108SC has high efficiency, low standby power consumption, low EMC and low cost.

Start up Control

S1108SC has very low start-up current that is less than 10uA. Therefore, a large resistor can be used in start-up circuit of switch power supply. This will minimize standby dissipation. The typical resistance of start-up resistor is 4M ohms.

Operating Current

The Operating current of S1108SC is less than 1.5mA. Therefore, S1108SC can have good efficiency.

Frequency shuffling for EMI improvement

The frequency Shuffling is implemented in S1108SC. The oscillation frequency is modulated with a random source so that the harmonic energy is spread out. The spread spectrum minimizes the conduction EMI and therefore reduces system design challenge.

Burst Mode Operation

At zero load or light load condition, the main power dissipation in a switching mode power supply is from switching on the MOSFET, the core of transformer and the snubber circuit. The magnitude of power dissipation is proportional to the number of switching frequency within certain period. Less switching frequency can reduce the power dissipation. S1108SC adjusts the switching frequency according to the loading condition. The PWM pulse width is kept greater than 1.2uS at any load condition. From light load to no load, the FB voltage drops. While the FB voltage is less than 1.1V, the gate pin output is disabled and kept low, while the FB voltage is higher than 1.2V, the gate output recovers to normal working mode. This is called 'burst mode'. To reduce audio noise, the switching frequency will be kept higher than 20KHz in burst mode.

Oscillator Operation

The switching frequency is internally fixed at 65kHz. No external frequency setting components are required on PCB design.

Current Sensing and Leading-Edge Blanking

Cycle-by-Cycle current limitation is offered in S1108SC. The switching current is detected by a resistor into the SENSE pin. An internal leading-edge blanking circuit chops off the SENSE voltage spike at initial so that the external RC filtering on SENSE pin is no longer required. The current limiting comparator is disabled and thus cannot turn off the external MOSFET during the blanking period. PWM duty cycle is determined by the voltage in the SENSE pin and the FB pin.

Internal Synchronized Slope Compensation

Slope compensation circuit adds voltage ramp onto the SENSE voltage according to PWM pulse width. This greatly improves the close loop stability at CCM and prevents the sub-harmonic oscillation and thus reduces the output ripple voltage. Slope compensation also help S1108SC obtain the same output current in universal ac input voltage.

Protection Controls

S1108SC has comprehensive protection functions, including Cycle-by- Cycle current limitation (OCP), Over Load Protection (OLP) and over voltage clamp, Under Voltage Lockout on VCC (UVLO), Over Temperature Protection (OTP).

Current limitation compensation

To obtain the same output current capability, the OLP threshold voltage is compensated for the different input AC voltage. This function makes the current of OLP is in consistency whatever the AC input is (110V or 220V).

**Package Information**

SOP8

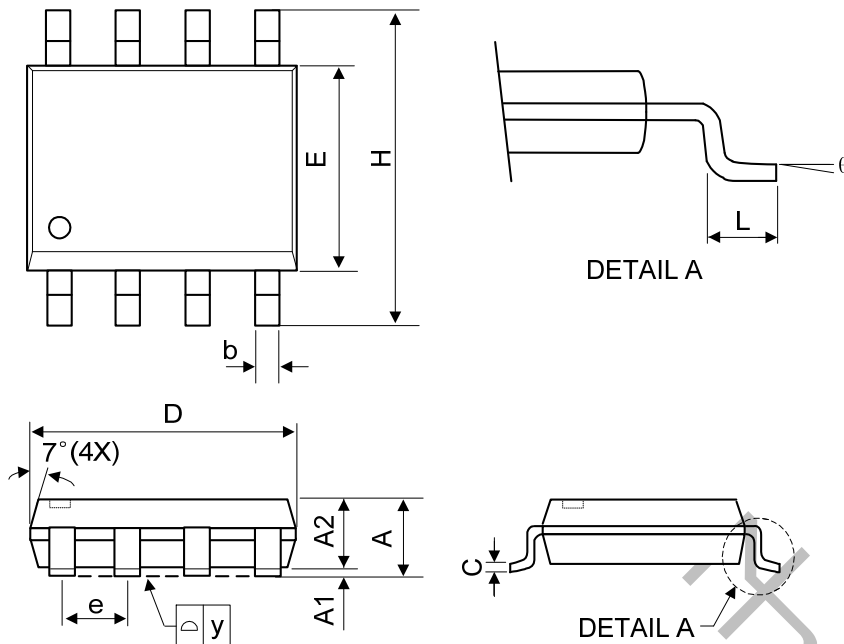

SYMBOL	MILLIMETER			INCHES		
	MIN	NOM	MAX	MIN	NOM	MAX
A	-	-	1.75	-	-	0.069
A1	0.1	-	0.25	0.04	-	0.1
A2	1.25	-	-	0.049	-	-
C	0.1	0.2	0.25	0.0075	0.008	0.01
D	4.7	4.9	5.1	0.185	0.193	0.2
E	3.7	3.9	4.1	0.146	0.154	0.161
H	5.8	6	6.2	0.228	0.236	0.244
L	0.4	-	1.27	0.015	-	0.05
b	0.31	0.41	0.51	0.012	0.016	0.02
e	1.27 BSC			0.050 BSC		
y	-	-	0.1	-	-	0.004
θ	0°	-	8°	0°	-	8°

Revision History

Version	Update date	Version By	Revised content
V0.91	2019-11-18	Li Wen	Preliminary
V0.92	2021-10-26	Li Wen	HV MOSFET