

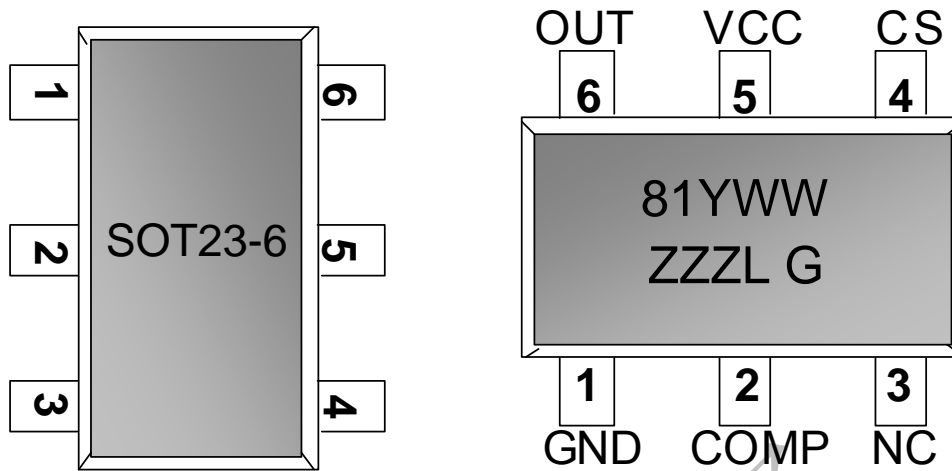

Pin Assignment & Marking Information



Y:	Year code (2022=N,2023=O,.....)
WW:	week code (01-52)
ZZZ:	LOT NO
L:	FAB code
E:	WAFER code

Ordering Information

Part number	Package	version number
S2281TMB	SOT23-6	

Pin Description

Symbol	Type	Description
GATE	O	Totem-pole gate diver output for the power MOSFET
VDD	P	Chip DC power supply pin
SENSE	I	Current sense input pin.
FB	I	Feedback input pin.
Gnd	P	Ground.



Block Diagram

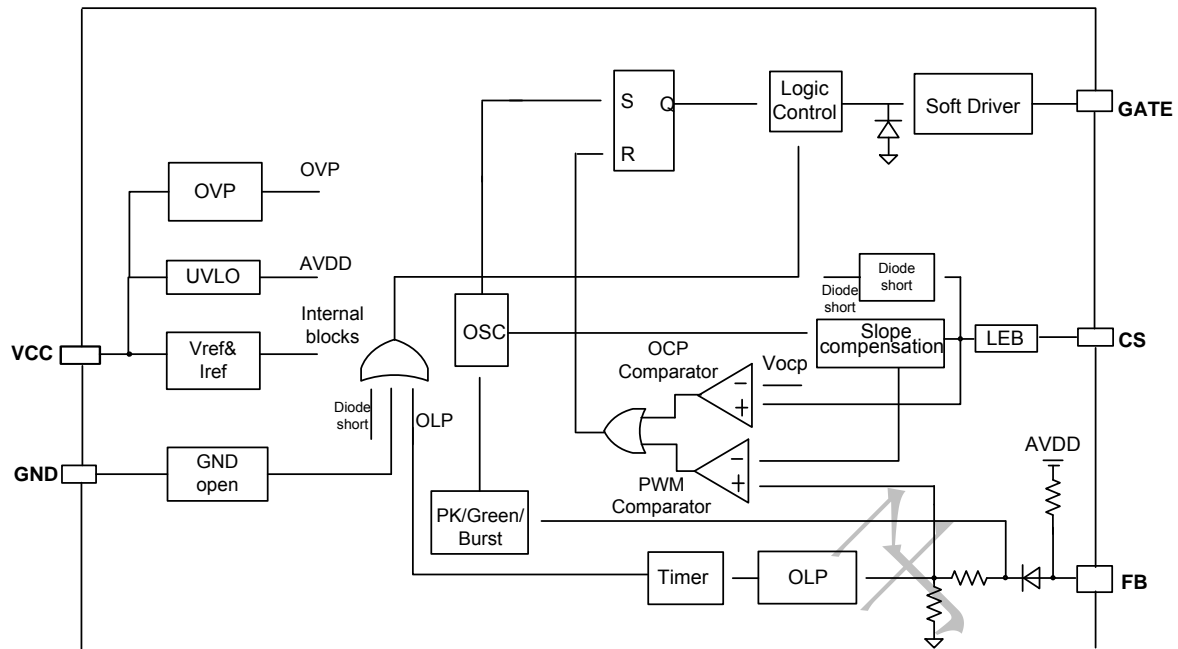

Absolute Maximum Rating

Parameter	Value	Unit
VDD clamp voltage	29	V
VDD clamp current	10	mA
VFB input voltage	-0.3 to 7	V
VSENSE input voltage to SENSE pin	-0.3 to 7	V
Min/Max operating junction temperature	-55 to 150	°C
Operating ambient temperature	-20 to 85	°C
Thermal resistance, Junction to ambient SOT23-6	250	°C/W

Note: Stresses above absolute maximum ratings may cause permanent damage to the device. Exposure to absolutely maximum-rated conditions for extended periods may affect device reliability.

Recommended Operating Conditions

Symbol	Parameter	Min. Max.	Unit
VDD	Supply Voltage Vcc	9 to 25.5	V
Toa	Operating Ambient temperature	-20 to 85	°C
ESD-HM	Human Model	2	KV
ESD-MM	Machine Model	150	V

**Electrical Characteristics** ($T_A = 25\text{ }^\circ\text{C}$, if not otherwise noted)

Symbol	Parameter	Conditions	Value			Unit
			Min	Typ	Max	
Supply Voltage (V_{dd} Pin)						
I _{dd_start-up}	VDD start-up current	VDD=12.5V		3	10	uA
I _{dd}	VDD Operation current	VDD=16V, FB=2V		1.5		mA
UVLO(ON)	VDD under voltage lockout enter		6.8	7.8	8.2	V
UVLO(OFF)	VDD under voltage lockout exit		13	13.4	16.5	V
OVP	VDD over voltage protection		25.5	26.5	28	V
Voltage Feedback (FB Pin)						
AVCS	PWM input gain	VFB/VSENSE		2		V/V
VFB _{open}	VFB open loop voltage			5.7		V
IFB _{short}	FB pin short current	Short FB pin to GND	90	150	300	uA
VFB _{burst}	Burst mode voltage			1.1		V
VTH _{PL}	Power limiting FB threshold voltage			3.7		V
TD _{PL}	Power limiting delay time			60		mS
DC _{MAX}	Maximum duty cycl	VDD=18V, SENSE=0V FB=2.2V		75		%
Current Sensing (SENSE Pin)						
T _{blanking}	Leading-edge blanking time		100	400	750	nS
ZSENSE _{IN}	Input impedance			40		K Ω
VTH _{sense}	Over current threshold voltage	Duty=0%	0.62	0.65	0.68	V
Oscillator						
F _{osc}	Normal oscillation frequency		60	66.5	73	KHz
Δ f _{temp}	Frequency temperature stability	T _A = -20°C to 100°C		5		%
f _{VDD}	Frequency voltage stability	VDD=16.5V to 25V		5		%
F _{osc_BM}	Burst mode base frequency		17	25	28	KHz
Δ f _{OSC}	Frequency modulation range Base frequency		-5		+5	%
Gate Drive Output						
VOL	Output low level	VDD=16V, IO=-20mA			0.8	V
VOH	Output high level	VDD=16V, IO=20mA	10			V
V _{Clamp}	output clamp voltage level			12		V
T _r	Output rising time	VDD=16V, CL=1nF		1300		nS
T _f	Output falling time	VDD=16V, CL=1nF		50		nS



Application Information

S2281TMB is a highly integrated PWM control IC for the flyback converter. S2281TMB is designed specifically for switching power supply that requires level 6 energy-efficiency. The input power is less than 75mW at No-load condition in universal input voltage rang.

Start up Control

S2281TMB has very low start-up current that is less than 10uA. Therefore, a large resistor can be used in start-up circuit of switch power supply. This will minimize standby dissipation. The typical resistance of start-up resistor is 4M ohms.

Operating Current

The Operating current of S2281TMB is less than 1.5mA. Therefore, S2281TMB can have good efficiency.

Frequency shuffling for EMI improvement

The frequency Shuffling is implemented in S2281TMB. The oscillation frequency is modulated with a random source so that the harmonic energy is spread out. The spread spectrum minimizes the conduction EMI and therefore reduces system design challenge.

Burst Mode Operation

At zero load or light load condition, the main power dissipation in a switching mode power supply is from switching on the MOSFET, the core of transformer and the snubber circuit. The magnitude of power dissipation is proportional to the number of switching frequency within certain period. Less switching frequency can reduce the power dissipation. S2281TMB adjusts the switching frequency according to the loading condition. The PWM pulse width is kept greater than 1.2uS at any load condition. From light load to no load, the FB voltage drops. While the FB voltage is less than 1.1V, the gate pin output is disabled and kept low, while the FB voltage is higher than 1.2V, the gate output recovers to normal working mode. This is called 'burst mode'. To reduce audio noise, the switching frequency will be kept higher than 20KHz in burst mode.

Oscillator Operation

The switching frequency is internally fixed at 65kHz. No external frequency setting components are required on PCB design.

Current Sensing and Leading-Edge Blanking

Cycle-by-Cycle current limitation is offered in S2281TMB. The switching current is detected by a resistor into the SENSE pin. An internal leading-edge blanking circuit chops off the SENSE voltage spike at initial so that the external RC filtering on SENSE pin is no longer required. The current limiting comparator is disabled and thus cannot turn off the external MOSFET during the blanking period. PWM duty cycle is determined by the voltage in the SENSE pin and the FB pin.

Internal Synchronized Slope Compensation

Slope compensation circuit adds voltage ramp onto the SENSE voltage according to PWM pulse width. This greatly improves the close loop stability at CCM and prevents the sub-harmonic oscillation and thus reduces the output ripple voltage. Slope compensation can help S2281TMB obtain the same output current in universal ac input voltage.

Gate Drive

The GATE pin of S2281TMB has 300mA of sinking and 150mA of sourcing current capability. Therefore, the MOSFET would be turned on slowly and turned off fast so that S2281TMB has high efficiency and low radiation EMI. The highest voltage of drive voltage is clamped at 12V.

Protection Controls

S2281TMB has comprehensive protection functions, including Cycle-by- Cycle current limitation (OCP), Over Load Protection (OLP) and over voltage clamp, Under Voltage Lockout on VDD (UVLO), Over Temperature Protection (OTP).

Current limitation compensation

To obtain the same output current capability, the OLP threshold voltage is compensated for the different input AC voltage. This function makes the current of OLP is in consistency whatever the AC input is (110V or 220V).



Package Information

SOT-23-6

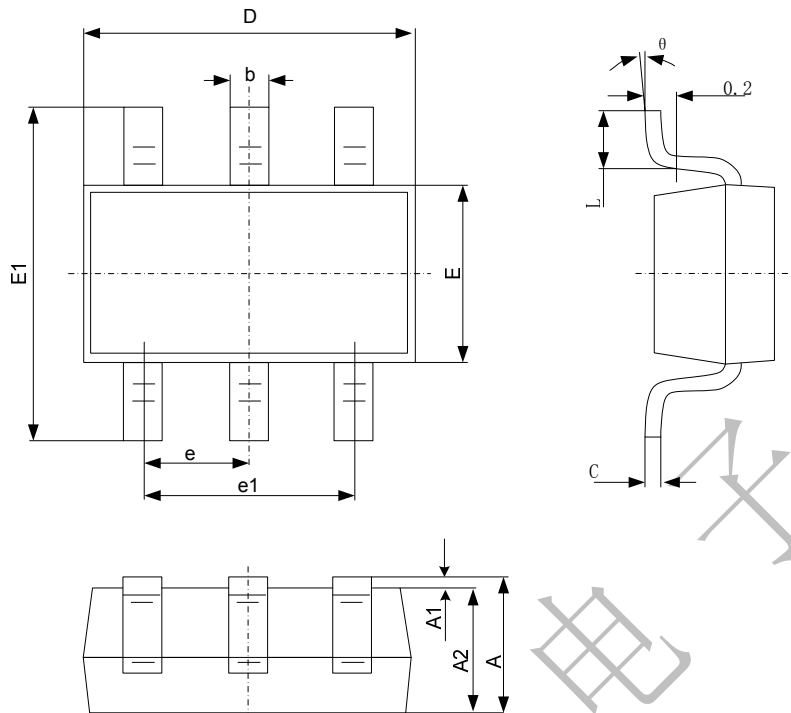

符号	尺寸 (毫米)		尺寸 (英寸)	
	最小	最大	最小	最大
A	0.900	1.200	0.035	0.047
A1	0.000	0.150	0.000	0.006
A2	0.900	1.100	0.035	0.043
b	0.300	0.500	0.012	0.020
c	0.100	0.200	0.004	0.008
D	2.800	3.020	0.110	0.119
E	1.500	1.700	0.059	0.067
E1	2.600	3.000	0.102	0.118
e	0.950 (中心到中心)		0.037 (中心到中心)	
e1	1.800	2.000	0.071	0.079
L	0.300	0.600	0.012	0.024
θ	0°	8°	0°	8°